



# OWNER'S GUIDE &

# INSTALLATION INSTRUCTIONS

Transom Mount *with Integrated Release Bracket*

Record the information found on the cable tag for future reference.

Part No. \_\_\_\_\_ Date \_\_\_\_\_ Frequency \_\_\_\_\_ kHz

## Depth Transducer

*with Temperature Sensor*

Depth & Temperature Model: **P66**

TRIDUCER® Multisensor: **P66**

Smart™ Sensor: **P66**

Chirp Model: **TM165HW**

Patent <http://www.airmar.com/patent.html>



TM165HW

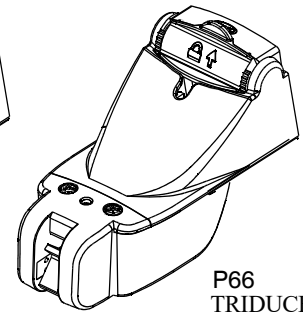
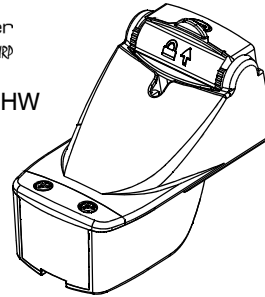

P66  
TRIDUCER®  
Multisensor

**Follow the precautions below for optimal product performance and to reduce the risk of property damage, personal injury, and/or death.**

**WARNING:** Always wear safety glasses, a dust mask, and ear protection when installing.

**WARNING:** When the boat is placed in the water, immediately check for leaks around the screws and any other holes drilled in the hull.

**CAUTION:** Do not attach the sensor to the bracket before fastening the bracket to the hull. It is VERY difficult to separate them if the bracket is unattached.

**CAUTION: TM165HW Chirp transducer**—Always operate the transducer in water. Operating in air will allow the transducer to overheat resulting in failure.

**CAUTION:** Never pull, carry, or hold the sensor by the cable as this may sever internal connections.

**CAUTION:** Never strike the transducer with anything except the palm of the hand. Never strike the paddlewheel.

**CAUTION:** The bracket protects the sensor from frontal impact only.

**CAUTION:** Never use solvents. Cleaner, fuel, sealant, paint, and other products may contain solvents that can damage plastic parts, especially the transducer's face.

**CAUTION:** Never power sand or pressure wash the sensor. It may weaken the structure or damage the internal components.

**IMPORTANT:** Please read the instructions completely before proceeding with the installation. These instructions supersede any other instructions in your instrument manual if they differ.

## Applications

- Recommended for boats up to 8m (25')
- Not recommended for boats with inboard engine(s)
- Not recommended for a stepped hull
- Adjusts to *transom* angles from 2° – 22°
- Vertically orients sound beam on hull with *deadrise* angle up to 28°
- Good operation up to 44kn (50MPH)

## Pretest Speed & Temperature Functions

Connect the sensor to the instrument and spin the paddlewheel. Check for a speed reading and the approximate air temperature. If there is no reading(s) or it is inaccurate, check the connections and repeat the test. If there is still no reading(s) or it is inaccurate, return the product to your place of purchase.

## Tools & Materials

Safety glasses

Dust mask

Ear Protection

Scissors

Masking tape

Electric drill

Drill bits and hole saws:

Bracket holes                    Ø 4mm, #23, or 9/64"

Transom hole (optional) 2mm or 1/16" larger than connector Ø

Cable clamp holes            Ø 3mm or 1/8"

Angle finder

Marine sealant (suitable for below waterline)

Screwdrivers

Straight edge

Pencil

Grommet(s) (some installations)

Cable ties

Water-based anti-fouling coating (**mandatory in salt water**)

02/19/21

17-247-03-rev.9

D-17-247-03-rev.9

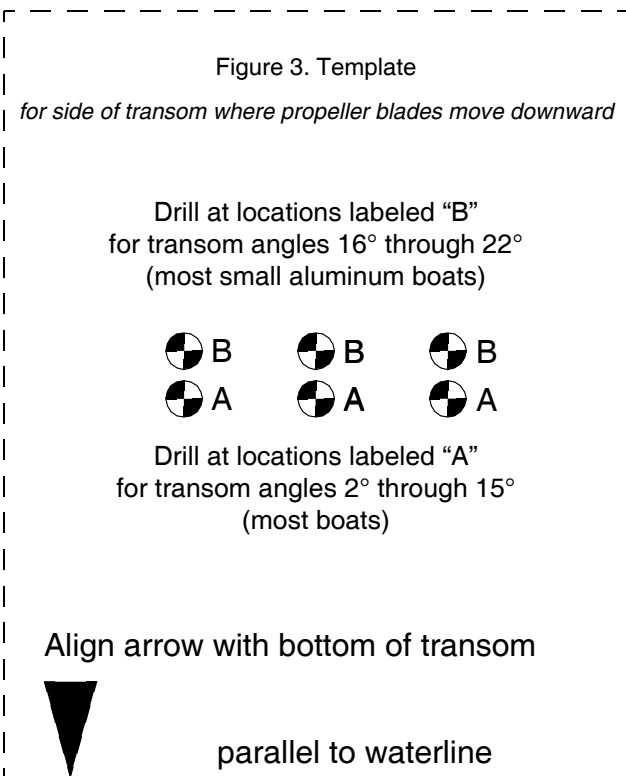
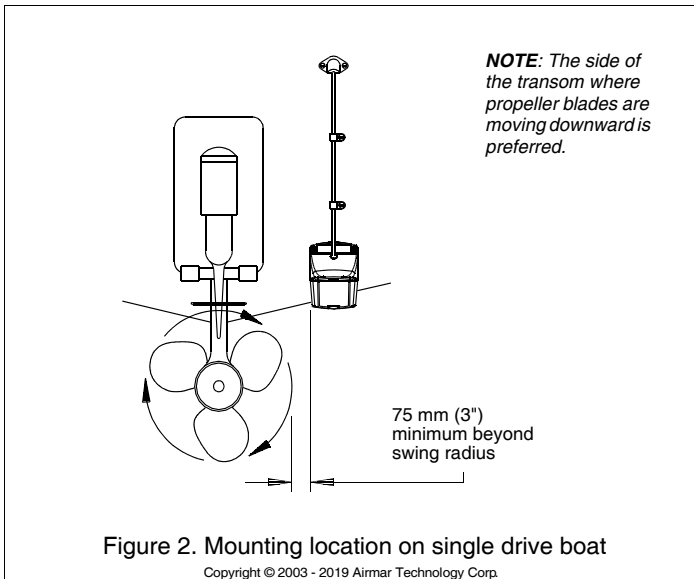
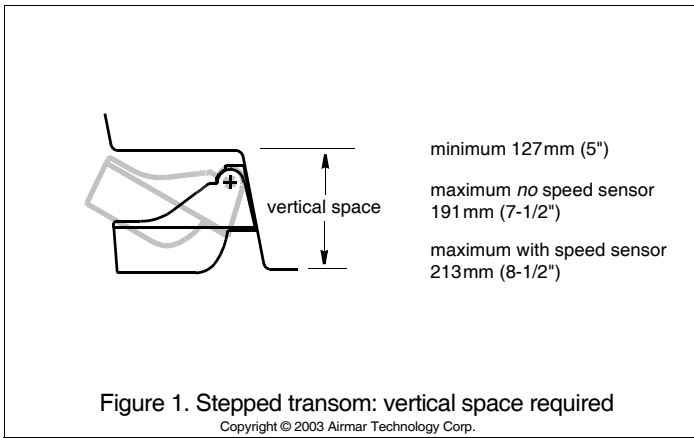

## Mounting Location

**CAUTION:** Do not mount the sensor in line with or near water intake or discharge openings or behind strakes, fittings, or hull irregularities that will disturb the water flow.

**CAUTION:** Do not mount the sensor in a location where the boat may be supported during trailering, launching, hauling, or storage.

- For the best performance, the sensor must be in contact with smooth water. To identify an area of "clean" water, observe the water flow off the transom while the boat is underway.
- Allow vertical space above the bracket for it to release and rotate the sensor upward (Figure 1).
- Mounting the sensor on the side of the transom where the propeller blades are moving downward is preferred (Figure 2).
- Mount the sensor as close to the centerline (keel) of the boat as possible to ensure the transducer's face remains in the water when the boat is turning.
  - **Single drive boat**—Mount the sensor at least 75mm (3") beyond the swing radius of the propeller.
  - **Twin drive boat**—Mount the sensor between the drives.
  - **Trim tabs**—Mount the sensor inside the trim tab, space permitting.
  - **Stepped transom**—Mount the sensor on the lowest step being sure there is enough space above the bracket for it to release and rotate the sensor upward (Figure 1).

## Installation

**CAUTION:** Install the bracket before attaching the sensor.

### Hole Drilling

**CAUTION:** To prevent drilling too deeply, wrap masking tape around the bit 22mm (7/8") from the point.

**NOTE: Fiberglass hull**—Minimize surface cracking by running the drill in reverse until the gelcoat is penetrated.

1. Cut out the template (Figure 3).
2. At the selected mounting location on the side of the transom where the propeller blades are moving downward, position the template, so the arrow at the bottom is aligned with the bottom edge of the transom (Figure 4). *Being sure the template is parallel to the waterline, tape it in place.*
3. Using a 4mm, #23, or 9/64" bit, drill three holes 22mm (7/8") deep at the marked locations.

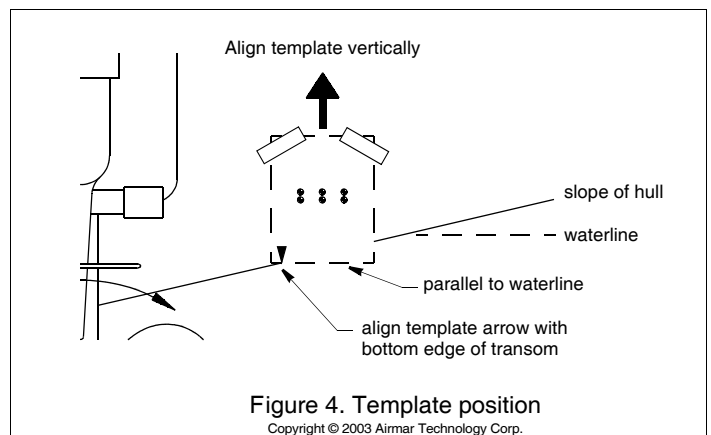

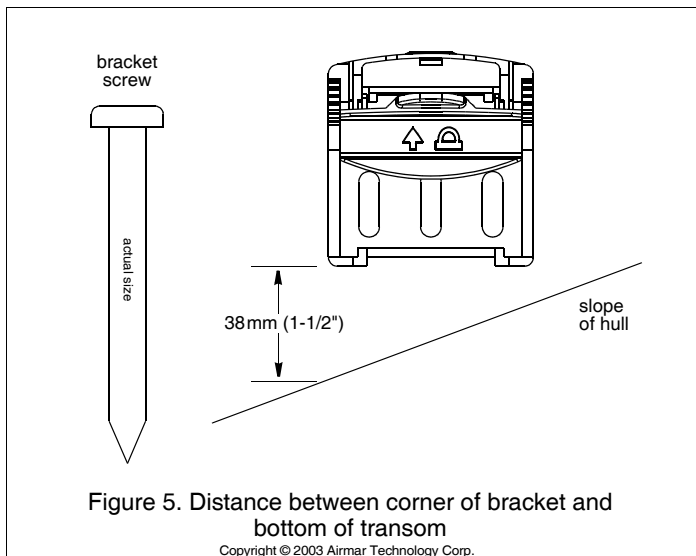

### Compensating for the Transom Angle: Shim

For the best performance, the transducer beam must be aimed straight at the bottom. Since the transom of most boats is angled, the bracket must compensate for it. Measure the transom angle of the boat with an angle finder.

**CAUTION: For boats capable of speeds above 20kn (28MPH)**—The trailing edge of the sensor must be deeper in the water than the leading edge. This will ensure that the paddlewheel is in contact with the water at high speeds.

- **Standard transom** (12° transom angle)—The bracket is designed for a standard 12° transom angle. The shim is not needed for this installation. Go to "Mounting the Bracket."
- **Stepped transom and jet boats** (3° transom angle)—Use the shim with the taper *down* (Figure 11).
- **Small aluminum and fiberglass boats** (20° transom angle)—Use the shim with the taper *up* (Figure 11).
- **If you are unsure about using the shim**—Experiment with the shim. Follow the instructions: "Mounting the Bracket," "Attaching the Sensor to the Bracket," and "Checking the Angle and Projection."

### Mounting the Bracket

1. Apply marine sealant to the threads of the three, #10 x 1-3/4", self-tapping screws to prevent water seepage into the transom (Figure 5). Screw the bracket (and shim if needed) to the hull. *Do not tighten the screws at this time.*
2. Using the vertical adjustment space on the bracket slots, slide the bracket up or down until the distance between the bottom left corner and the bottom of the transom equals 38mm (1-1/2"). Tighten the screws.

### Stepped Transom Only

If there is insufficient space under the step for the sensor to fully release, remove the cover before proceeding (Figure 1, maximum space). This is necessary to access the bracket screws at a later time.

1. Remove the two screws that hold the speed sensor onto the transducer housing (Figure 6).
2. The paddlewheel assembly is a loose slip fit. Carefully, slide the speed sensor upward while keeping the paddlewheel assembly inside (Figure 7).
3. Insert a blade screwdriver between the cover and the transducer housing (Figure 8). Pry each side apart, in turn.
4. Lift the cover up and off.

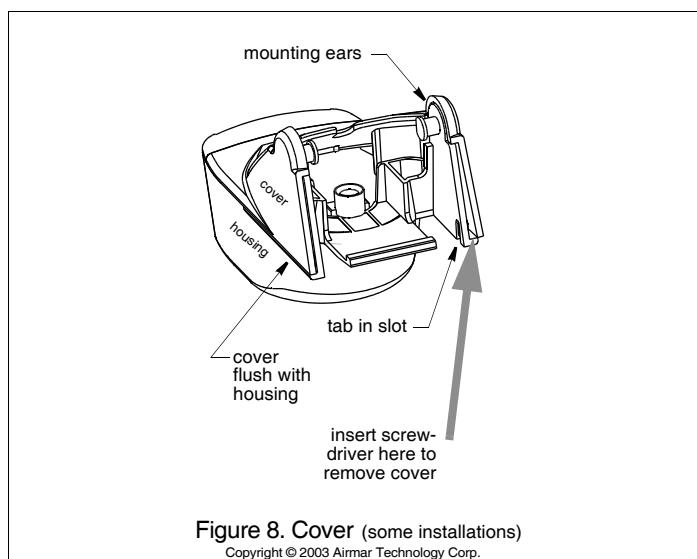
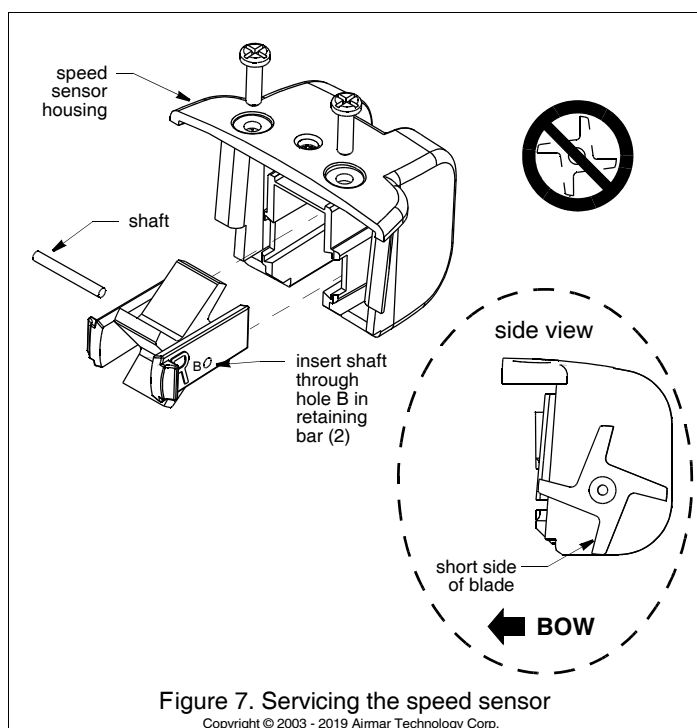
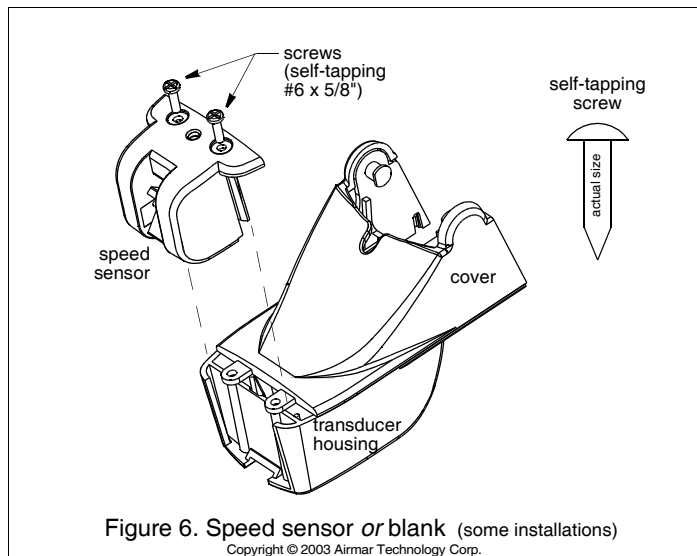

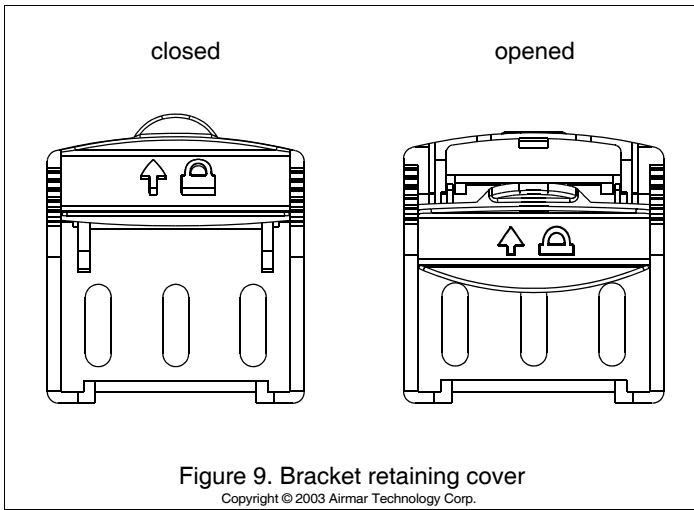

### Attaching the Bracket to the Sensor

**CAUTION:** The retaining cover must be closed and latched to prevent the sensor from coming off the bracket when the boat is underway.

1. If the retaining cover is closed, open it by depressing the latch and rotating the cover downward (Figure 9).
2. Insert the sensor's pivot posts into the slots in the top of the bracket (Figure 10). Push down until the posts click into place.
3. Rotate the sensor downward until it snaps onto the bracket.
4. Close the retaining cover by rotating it upward until it latches.

### Checking the Sensor Angle & Projection

**CAUTION:** Do not position the leading edge of the sensor deeper in the water than the trailing edge because aeration will occur.

**CAUTION:** Do not position the sensor deeper into the water than necessary to avoid increasing drag, spray, and water noise and reducing boat speed.

1. Using a straight edge, sight the underside of the sensor relative to the underside of the hull (Figure 11). The trailing edge of the sensor should be 1–3mm (1/16–1/8") below the leading edge of the sensor or parallel to the bottom of the hull.
2. Check that the bottom left corner of the sensor projections 3mm (1/8") below the bottom of the hull (Figure 12).
3. If the sensor needs adjustment, release it upward (see "Releasing the Sensor" below). Adjust the bracket. Tighten the screws.

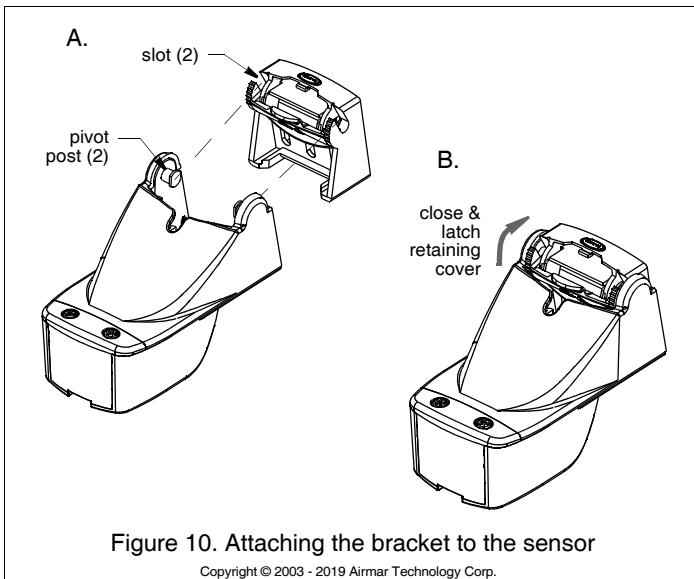

### Releasing the Sensor

Do one of the following (Figure 13):

- *Using the palm of your hand*, give a sharp upward blow to the underside of the transducer housing. Do not hit the speed sensor.
- Insert a blade screwdriver between the transducer housing and the bottom of the bracket (either side). Push up on the screwdriver while lifting up on the sensor.

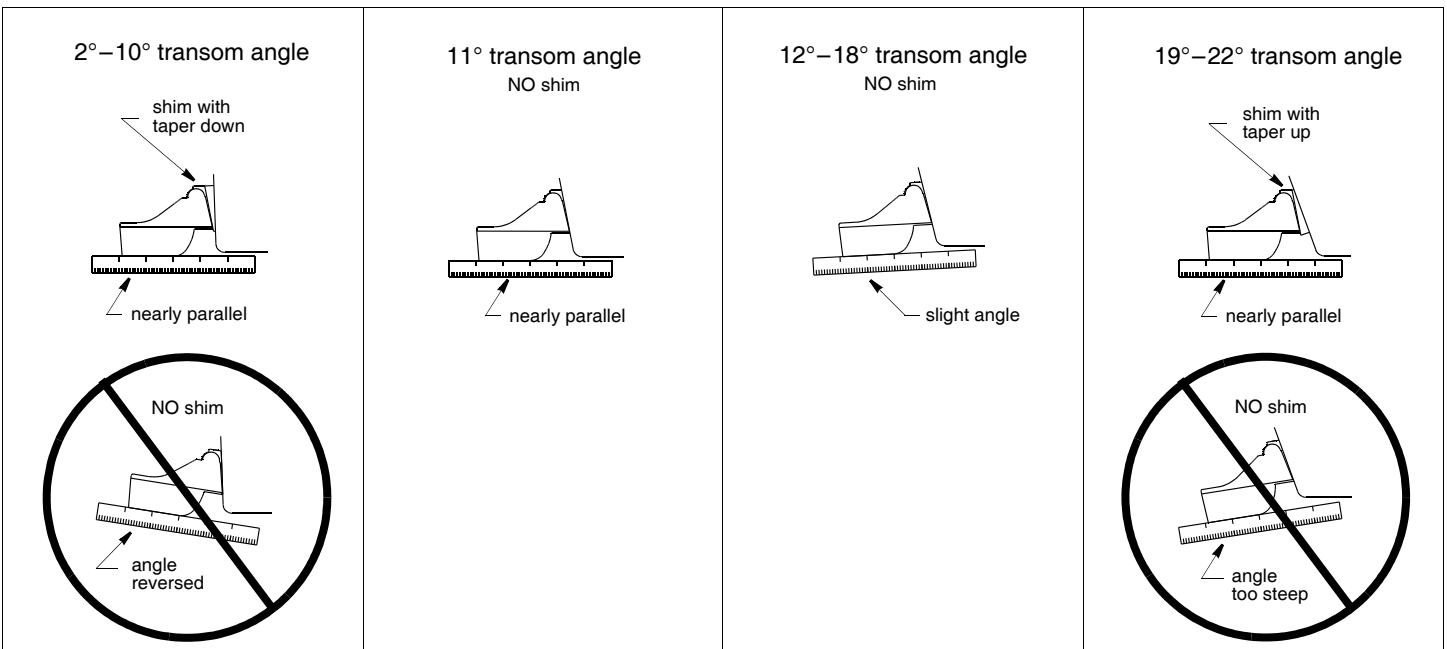

## Attaching the Speed Sensor or the Cover & Blank

(some installations)

1. Spread the sides of the cover horizontally (Figure 8).
2. Slide the cover up and over the mounting ears.
3. Push the cover down until it sits flush on the transducer housing.
4. Squeeze the sides of the cover until the tabs snap into the slots.
5. Insert the side rails of the speed sensor or blank into the channels on the back of the transducer housing (Figure 6). Slide it downward. Fasten the speed sensor or blank in place with the two, #6 x 5/8", self-tapping screws.

## Testing on the Water

1. Become familiar with your echosounder's performance at a speed of 4kn (5MPH).
2. Gradually increase the boat speed and observe the gradual decline in performance due to turbulent water flowing under the transducer's face.
3. If the decline in performance is sudden (not gradual), identify the boat speed at which the onset occurred. Return the boat to this speed, then gradually increase speed while making moderate turns in both directions.
4. If the performance improves while turning to the side on which the sensor is installed, the transducer's position probably needs adjustment. It is probably in aerated water.

**To improve performance**, try the following one at a time, in the order given, in small increments.

- a. Increase the sensor's angle, so the back of the sensor is deeper in the water. Review "Checking the Sensor Angle & Projection" and Figure 11, 12° - 18°.
- b. Move the sensor deeper into the water in increments of 3mm (1/8") (Figure 12).
- c. Move the sensor closer to the centerline of the boat. Fill unused screw holes with marine sealant.

**NOTE: High-speed operation [above 35kn (40MPH)] may require less projection in the water to improve performance and reduce the chance that water pressure will cause the bracket to release. Move the sensor upward on the transom.**

5. **Calibration**—To match the speed shown on the display to the actual speed of the boat, you may need to calibrate the instrument. Refer to your instrument owner's manual.

## Cable Routing & Connecting

**CAUTION:** Do not remove the connector to ease cable routing. If the cable must be cut and spliced, use Airmar's splash-proof Junction Box No. 33-035 and follow the instructions provided. Removing the waterproof connector or cutting the cable, except when using a water-tight junction box, will void the sensor's warranty.

Route the sensor cable over the transom, through a drain hole, or through a new hole drilled in the transom **above the waterline**.

1. If a hole must be drilled through the transom, choose a location **well above the waterline** (Figure 12). Check for obstructions such as trim tabs, pumps, or wiring inside the hull. Mark the location with a pencil. Drill a hole using the appropriate size bit to accommodate the connector.
2. Route the cable over or through the transom.
3. On the outside of the hull, secure the cable against the transom using the cable clamps. Position one cable clamp 50mm (2") above the bracket and mark the mounting hole with a pencil.

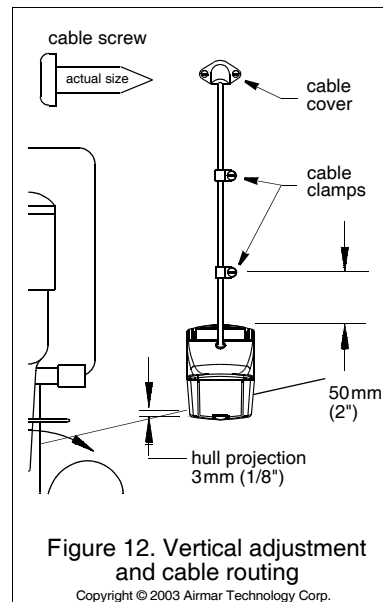

Figure 12. Vertical adjustment and cable routing

Copyright © 2003 Airmar Technology Corp.

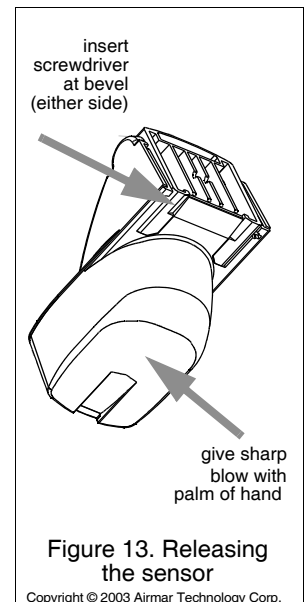

Figure 13. Releasing the sensor

Copyright © 2003 Airmar Technology Corp.

4. Position the second cable clamp halfway between the first clamp and the cable hole. Mark this mounting hole.
5. If a hole has been drilled in the transom, open the appropriate slot in the cable cover. Position the cover over the cable where it enters the hull. Mark the two mounting holes.
6. At each of the marked locations, use a 3mm or 1/8" bit to drill a hole 10mm (3/8") deep.
7. Apply marine sealant to the threads of the #6 x 1/2" self-tapping screws to prevent water from seeping into the transom. If you have drilled a hole through the transom, apply marine sealant to the space around the cable where it passes through the transom.
8. Position the two cable clamps and fasten them in place. If used, push the cable cover over the cable and screw it in place.
9. Route the cable to the instrument being careful not to tear the cable jacket when passing it through the bulkhead(s) and other parts of the boat. Use grommets to prevent chafing. To reduce electrical interference, separate the sensor cable from other electrical wiring and the engine(s). Coil any excess cable and secure it in place with cable ties to prevent damage.
10. Refer to your echosounder owner's manual to connect the sensor to the instrument.

## Checking for Leaks

When the boat is placed in the water, **immediately** check for leaks around the screws and any holes drilled in the hull. Note that very small leaks may not be readily observed. Do not leave the boat in the water unchecked for more than three hours.

## Maintenance

### Anti-fouling Coating

Surfaces exposed to salt water that *do not interlock*, must be covered with anti-fouling coating. Use a *water-based* anti-fouling coating made for transducers only. Never use ketone-based paint, since ketones can attack many plastics possibly damaging the transducer. Brush on anti-fouling coating every 6 months or at the beginning of each boating season.

## Cleaning

Aquatic growth can accumulate rapidly on the sensor's surface reducing performance within weeks. Clean the transducer's face with a Scotch-Brite® scour pad and mild household detergent taking care to avoid making scratches. If the fouling is severe, lightly wet sand with fine grade wet/dry paper.

## Servicing the Speed Sensor

**CAUTION:** The paddlewheel must be oriented correctly to measure boat speed.

If the paddlewheel becomes fouled or inoperable, remove it for cleaning. Remove the two screws from the speed sensor (Figure 14). Slide it upward to remove it from the transducer housing. Grasp the two retaining bars and pull to access the shaft.

After cleaning, slide the paddlewheel onto the shaft. *Orient the short side of the paddlewheel blade as shown on the side view. It must be oriented correctly to measure the boat's speed.* Fit the shaft into the holes marked "B" in the retaining bars. *Note: There is a left retaining bar marked with an L and a right retaining bar marked with an R. Slide the assembly into the speed sensor housing. Note: The interior of the housing is marked with a corresponding L and R.* Re-attach the speed sensor.

## Sensor Replacement & Parts

The information needed to order a replacement sensor is printed on the cable tag. Do not remove this tag. When ordering, specify the part number, date, and frequency in kHz. For convenient reference, record this information on the top of page one.

Lost, broken or worn parts should be replaced immediately. The water-lubricated paddlewheel bearings have a life of up to 5 years on low-speed boats [less than 10kn (11MPH)] and 2 years on high-speed vessels. Some depth/temperature units can be upgraded by adding a speed sensor. Obtain parts from your instrument manufacturer or marine dealer.

### Gemeco

### USA

Tel: 803-693-0777

Email: sales@gemeco.com

### Airmar EMEA

### Europe, Middle East, Africa

Tel: +33.(0)2.23.52.06.48

Email: sales@airmar-emea.com

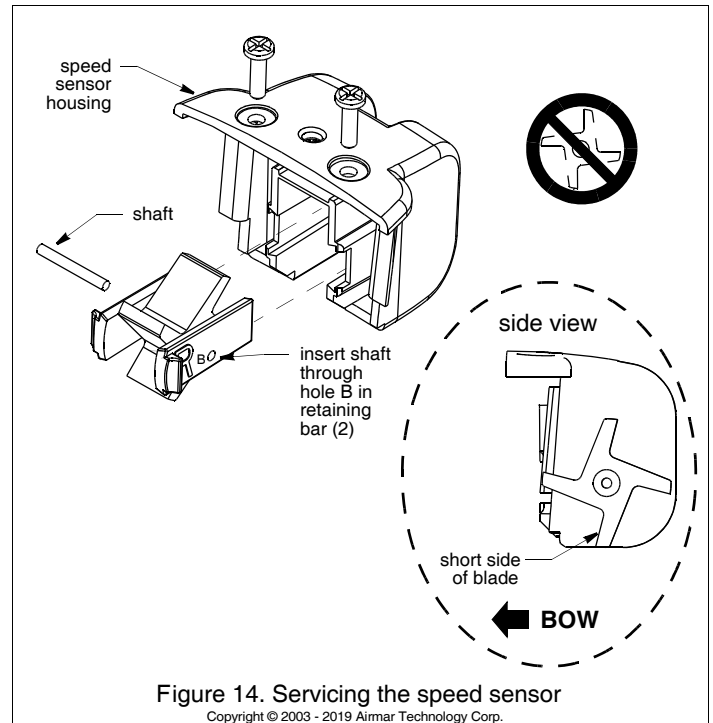

Smart™ Sensors only



35 Meadowbrook Drive, Milford, New Hampshire 03055-4613, USA  
www.airmar.com

Copyright © 2000 - 2021 Airmar Technology Corp. All rights reserved.

## REMOVABLE NUT ASSEMBLY INSTRUCTIONS

1. Feed the cable/connector through the 13/16" (21 mm) diameter hole in the wall.
2. Slip the nut over the connector and push it past the connector and over the cable.
3. Insert the wedge tool into the groove in the split of the split ring. Slide the wedge tool until its squared end is flush with the larger edge of the split ring.
4. Slip the split ring and wedge tool over the connector body until aligned with the mounting groove on the connector.
5. Remove the wedge tool and seat the split ring in the mounting groove, making sure the connector protrusion falls into the split.
- Note: Slip the o-ring up to the split ring.*
6. Slip the nut forward until it stops at the connector. Twist until the protrusions on the inside of the nut align with the grooves on the split ring.
7. Slip the nut forward and snap it into place.

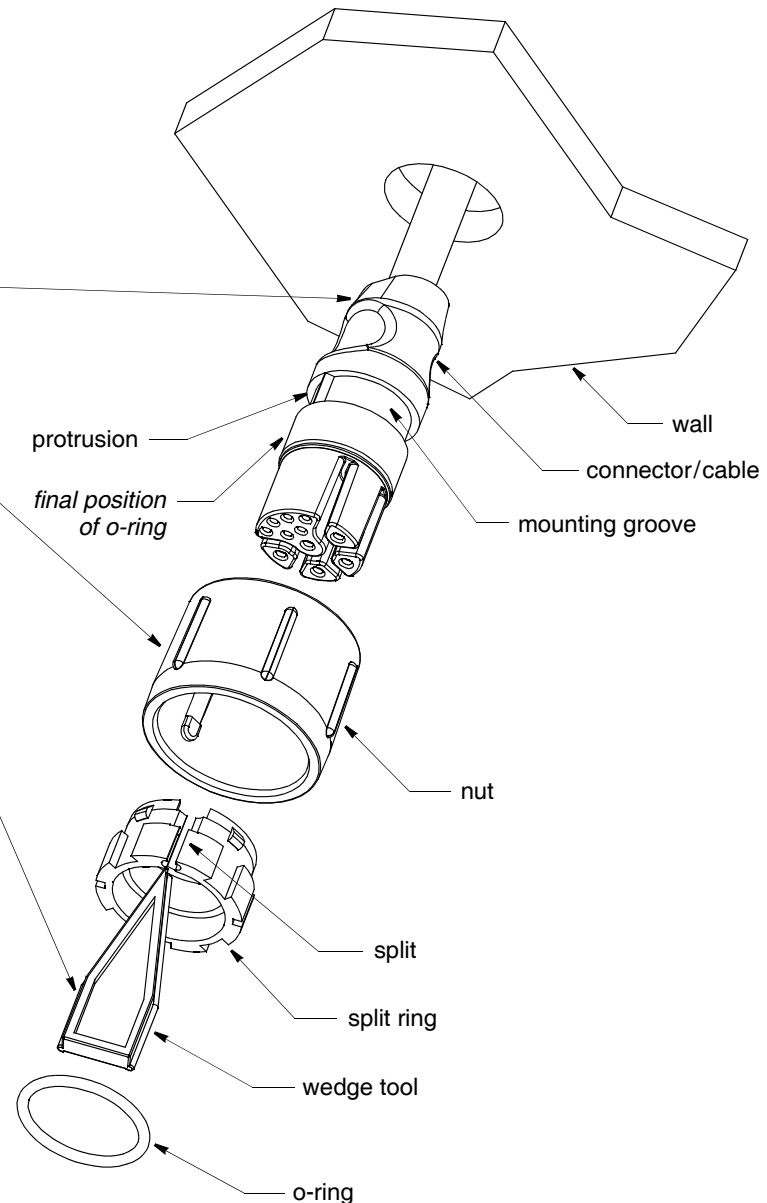

# INSTALLATION INSTRUCTIONS



## Connector with Removable Nut Assembly

1. Feed the connector and cable through the 13/16" (21 mm) diameter hole in the bulkhead.
  2. Slip the nut over the connector and push it past the connector and over the cable.
  3. Insert the wedge tool into the groove in the split of the split ring. Slide the wedge tool until its squared end is flush with the larger edge of the split ring.
  4. Slip the split ring and wedge tool over the connector body until aligned with the mounting groove on the connector.
  5. Remove the wedge tool and seat the split ring in the mounting groove, making sure the connector protrusion falls into the split.
- NOTE:** Slip the o-ring up to the split ring.
6. Slip the nut forward until it stops at the connector. Twist until the protrusions on the inside of the nut align with the grooves on the split ring.
  7. Slip the nut forward and snap it into place.

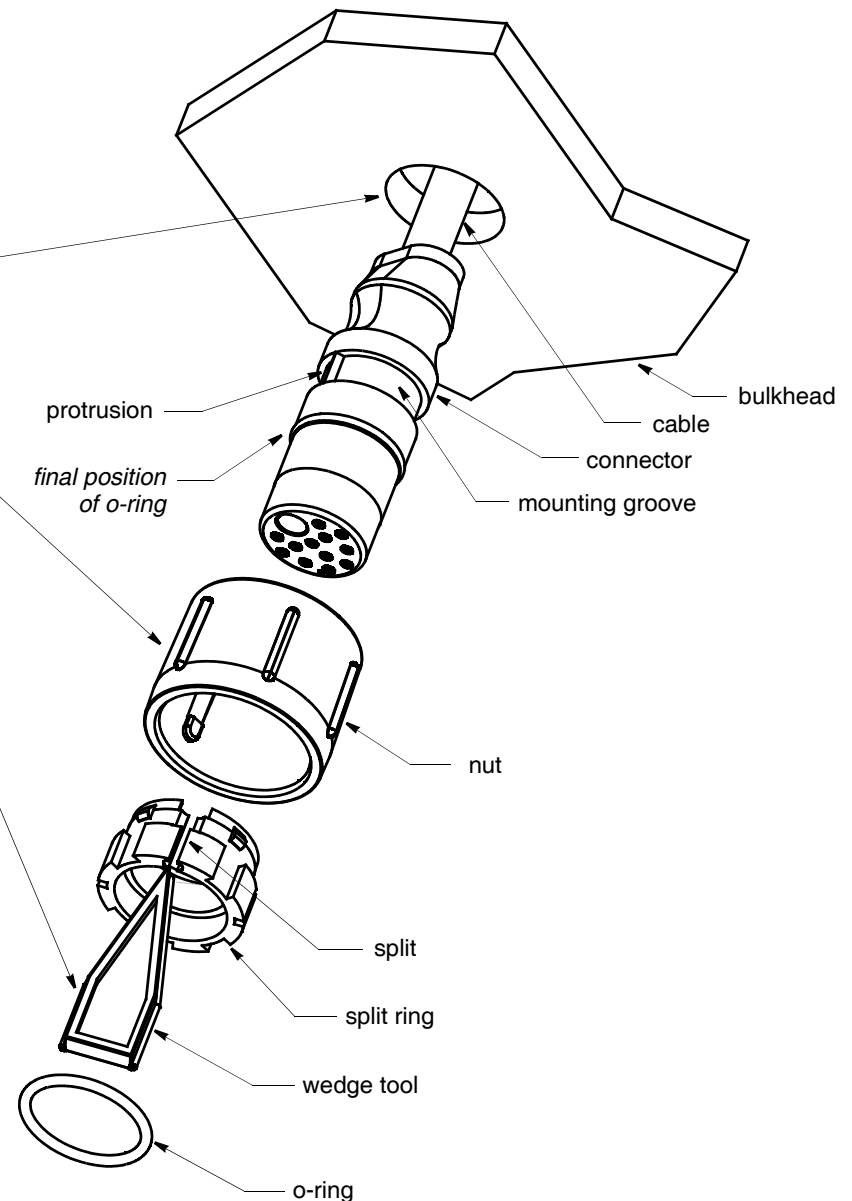





# AVOID OVERHEATING

## Installation Supplement: *Chirp* Transducers



**CAUTION:** Follow the instructions that came with your transducer. To install a Chirp transducer in a way other than intended by the manufacturer may lead to the transducer overheating, resulting in transducer failure.

Due to the nature of Chirp technology, Chirp transducers generate more heat than traditional tone-burst transducers operating at the same frequency. Chirp transducers have heat sinks in their construction to dissipate heat. Airmar's Chirp transducers have been designed to be installed in specific ways according to the number and placement of these heat sinks.

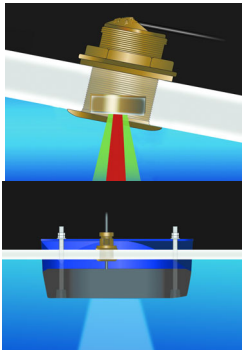

### Thru-Hull Mount: Low-Profile

Models: B75L/M/H/HW, B150M, B175L/M/H/HW, SS75L/M/H, SS175L/M/H/HW  
Transducer is installed in a hole drilled through the hull at a cool location away from the engine compartment. During operation, the active face of the transducer is in contact with water.



### Thru-Hull Mount: External or Stem

Models: B265LH/LM, B275LHW, B285M/HW, B765LH/LM, B785M, M188LH, R109LH/LM/LHW, R409LWM, R509LH/LM/LHW  
Transducer is installed entirely outside of the hull. A stem or stuffing tube hole is drilled through the hull for the transducer cable. The active face and sides of the transducer are immersed in water.

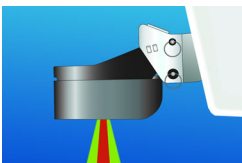

### In-Hull Mount

Models: M135M, M265LH/LM, M285HW, P75M, P95M, P155M, R111LH/LM, R599LH/LM

Transducer is installed within a wetbox/yellow plastic tank affixed inside the hull at a cool location. It must be away from the engine compartment and other hot places. No holes are drilled in the hull, however this installation is suitable for a solid fiberglass hull only. The active face and the sides of the transducer are immersed in propylene glycol (non-toxic marine/RV anti-freeze).



### Cavity Mount: Keel

Models: CM265LH/LM, CM275LHW, CM510L, CM599LH/LM/LHW, PM111LH/LM/LHW, PM411LWM

Transducer is installed in a cavity in the keel at a cool location away from the engine compartment. The active face of the transducer is flush with the outside of the hull and in contact with water.

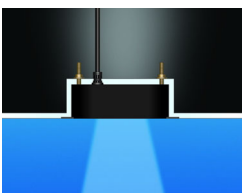

### Cavity Mount: Pocket

Models: CM265LH/LM, CM275LHW, CM510L, CM599LH/LM/LHW, PM111LH/LM/LHW, PM265LH/LM, PM275LHW, PM411LWM

Transducer is installed in a cavity in the hull at a cool location away from the engine compartment. The active face of the transducer is flush with the outside of the hull and in contact with water.

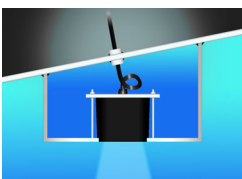

### Welded-tank Mount

Models: CM265LH/LM, CM275LHW, CM510L, CM599LH/LM/LHW, PM111LH/LM/LHW, PM411LWM

Transducer is installed in a water-filled, welded tank outside of the hull. The active face and sides of the transducer are immersed in water.

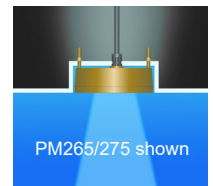

# **FOULFREE**™

**AIRMAR**® CERTIFIED TRANSDUCER COATING\*

## Protect your transducer

Keep your transducer clear  
with Foulfree™ transducer coating



\* AIRMAR certifies that the application of Foulfree coating on its transducers results in no loss in transducer performance.

## Transducer defense. Foul-release.

Airmar and PropSpeed® bring you Foulfree, a nontoxic, long-lasting, ultra-smooth surface that prevents marine fouling from sticking to the coated surface.

Marine growth on a transducer can negatively affect sonar performance, including significant turbulence noise on the screen while running or reducing the amount of detail on the sonar image received when fishing. Keeping the transducer free from growth and fouling ensures top performance from your transducer.

### Easy to apply and long-lasting

One 15ml tube of Foulfree covers one square foot (0.09m<sup>2</sup>) area of transducer. Once applied, the surface will continue to protect for up to two years.

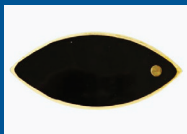

#### *Transducer safe*

Foulfree is Airmar certified and has no adverse effects on its transducers.

#### *Nontoxic and eco-friendly*

Once cured, Foulfree will not release any toxins into the environment.

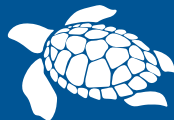

#### *Foul-release, not anti-foul*

A super slick coating that marine growth cannot stick to.